

Transfer or duplication of this document as well as the utilization or communication of its contents are prohibited unless authorized in writing by the copyright owner. All rights reserved for patent, utility model or design registrations. 除专利、实用新型、外观设计、发明专利权等权利外，本公司保留对涉及发明、实用新型、外观设计、发明专利权等权利的所有权利。

未注公差/General tolerances (mm)													0.1/10	
0	>3	>6	>10	>18	>30	>50	>80	>120	>180	>250	>315	>400		>500
~3	~6	~10	~18	~30	~50	~80	~120	~180	~250	~315	~400	~500	~500	
±0.12	±0.18	±0.22	±0.26	±0.31	±0.37	±0.57	±0.80	±0.93	±1.05	±1.15	±1.60	±2.20	±2.50	±2'

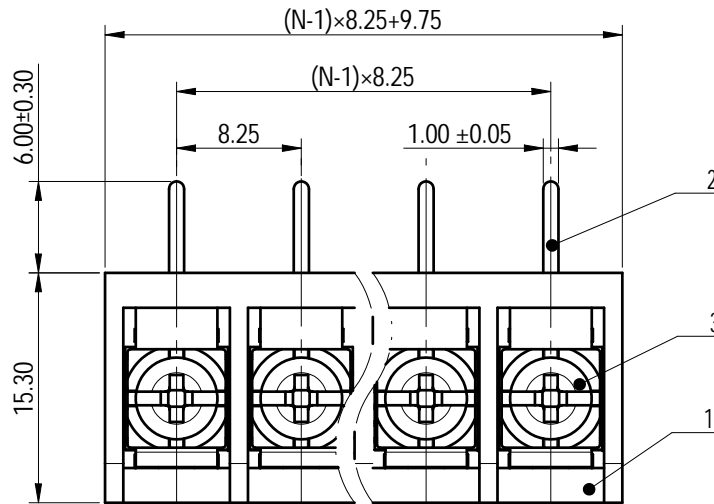

UL 标准/UL Standard:	B	C	D
额定电压/电涌/Rated Voltage(V)/Current(A)	300/20	/	/
螺丝扭矩/Torque Tightening(N·m/Lb.in)	M3, 0.5/4.43		
线径范围(硬线和软线)/Wire Range(rigid and flexible)(AWG)	22~12		
间距/Pitch(mm)/线数范围/Poles	8.25/N=02~22P		
使用温度范围/Operating temperature(°C)	-40~+105		
符合RoHS环保要求/Conform to RoHS	Yes		

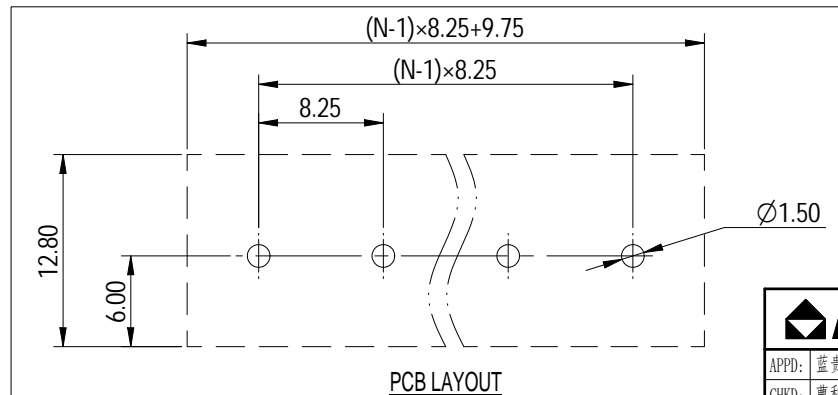
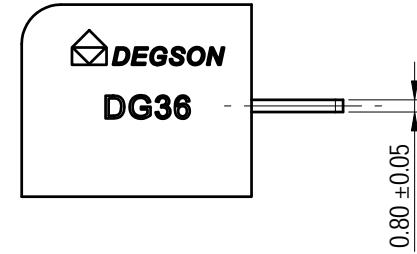
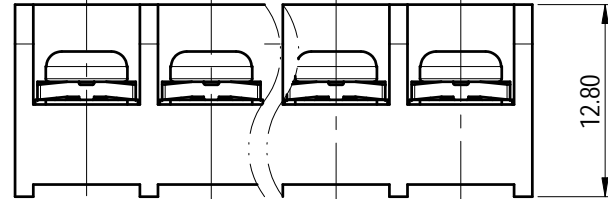
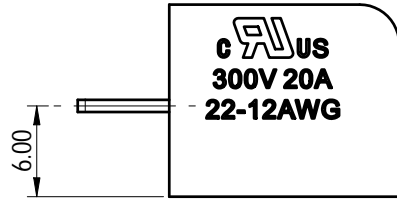

Note: The A&Z(H) in the name means: A(H) and Z(H).

3	Screw	Steel	Ni Plated
2	Pin header	Copper alloy	Sn Plated
1	Housing	PA66	UL94V-0
ITEM	NAME OF PART	MATERIAL	NOTES

<b>DEGSON</b>		MATERIAL:	SURFACE/COLOR:		
APPD: 蓝贵凡 2023.06.06		MAT NO./REV: - / 00	MAT STATUS: 批量		
CHKD: 曹利彬 2023.06.06		NAME			
DRFT: 姜民洁 2023.06.06		DG36R-B-XXP-1Y-00A&Z(H)			
DRAWING NO.	TYPE	DRAWING STATUS	SCALE	SHEET	
200059815	CUSTOMER DRAWING	已发布	2:1	1/1	

00					
REV	ECN	DESCRIPTION	DRFT	DATE	